

B² audio

MODEL: QUOTA

Product id:QUOTA11D

Quota

OWNER'S MANUAL



Foreword

We congratulate you with your decision to purchase our revered niche amplifiers. Every product developed by B^2 implements the keystones of our company philosophy; Optimum sound reproduction within its range **B**etter **B**ass & high performance. These elements will enable you to reproduce music the way you prefer.

Our amplifiers features a unique design, a variety of applications & highest possible efficiency combined with a clean analytical sound.

To obtain the full potential of the amplifier, we recommend to upgrade the stock electrical system. Even so, our amplifiers are engineered to deliver high power output levels with the OEM electrical system.

In order to minimize errors and increase performance, read through the whole manual. Installation can preferably be carried out by an authorized B^2 dealer.

Visit us at: <http://b2audio.com> & at facebook; <http://facebook.com/b2audio>
Interested in competing with our products? As a proud sponsor of the elite organisation within sound, dB Drag Racing & Bass Race you can easily get started. Visit Termpro.com for more information.



Better Bass

Better Bass is our philosophy of adding something extra. Keep in mind that continuous exposure to SPL above 100 dB can seriously damage your hearing. Today's high power auto sound systems can easily produce SPL over 140 dB. Enjoy your music with sense.

Table of contents

1. Design features	3	3.1 Installation considerations	5
		3.2 Power connectors	5
2. Panel layout	4	3.3 Wiring layout	6
		3.31 Speaker wiring diagram.....	6
3. Installation	5 - 6	4. Troubleshooting	7

1. Design features

Quota

Circuit Configuration	HI-EF Class D Mono
Frequency Response	: 15Hz ~ 280Hz
Signal to Noise Ratio	: 90dB
Input Sensitivity	: 6V ~ 0.2V
Input Level Selector	: -
Crossover	: 12dB / Oct
Low Pass Crossover Range	: 35Hz ~ 250Hz
Subsonic Crossover	: 35Hz
Bass Boost	: 0 ~ 9dB
Variable Bass Boost Range	: 35Hz ~ 100Hz
Remote Control	: Optional
Damping Factor	: 250<
Power Terminal gauge	: 4 ga
Fuse Rating	: 90A

All features are subject to change in the continuing effort to improve the products without notice.

Specifications

Continious output power rating (RMS)

Quota

Power @ 4 Ω
400 W x 1

Power @ 2 Ω
650 W x 1

Power @ 1 Ω (14,4V < 1% THD)
1000 W x 1

Power @ 4 Ω
450 W x 1

Power @ 2 Ω -
700 W x 1

Power @ 1 Ω (14,4V < 5% THD)
1200 W x 1

Specifications (detailed)

- 1) The *Quota* operates stable @ impedances of minimum 1 Ω mono.
 - Running the *Quota* at these impedances sets requirements to ventilation & the battery system.
- 2) The amplifier has a 4 stage advanced protection circuit;
 - Thermal protection, Voltage sensors, DC offset & short circuitry via speaker outputs.
- 3) The *Quota* utilizes a double sided SMD pcb & high current mosfet switching devices in both the in- and output stage.
- 4) Awired remote level control is optional for the amplifier.
 - This unit will enable remote gain adjustment.
 - For more advanced features like selectable bass frequency, boost level & gain, the *Better Bass Remote* (optional) can be used.
- 5) The crossovers of the *Quota* are variable 12 dB/octave filters for both low pass & subsonic.

2. Panel layout

Quota

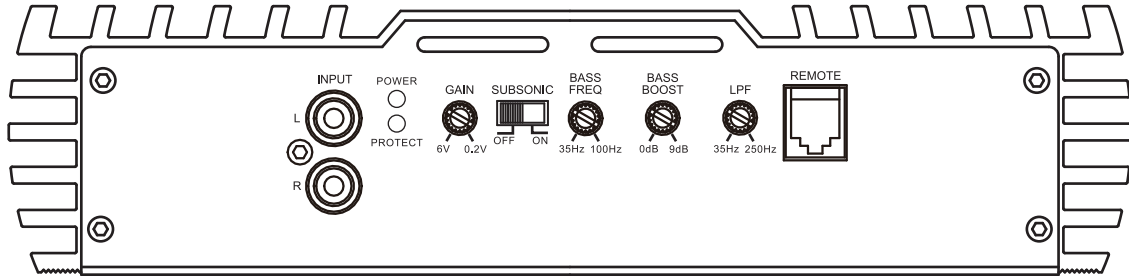

INPUT

Signal input from the head unit. A minimum level input of 0.2V is essential for correct operation.

POWER & PROTECTION INDICATOR

Power LED, Blue-lit shows correct operation. Protect LED, Red-lit shows general malfunction, faulty connection or thermal protection.

GAIN (6V ~ 0.2V)

Matching of the output voltage from the head unit's RCA line-outs to the input section.

SUBSONIC FILTER (35Hz @ 24dB/Oct)

On / Off mode of the subsonic filter to eliminate frequencies below the cut off point.

BASS FREQ

Adjustable bass frequency from 35 Hz ~ 100 Hz.

BASS BOOST

Variable bass boost with 0-9 dB.

LOW PASS FILTER

Adjusts the cut off point for the low pass filter within the filter's range.

REMOTE LEVEL CONTROL PORT

Connection of external level control. (The *Better Bass Remote* can be connected for additional features).

Power connectors

Quota

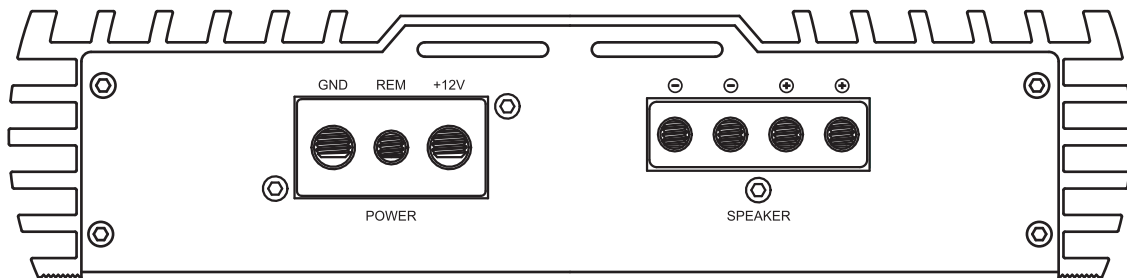

GND (GROUND CONNECTION)

For connection to the chassis' ground. For optimum performance 0 gauge cable is recommended.

+12V (POWER CONNECTION)

For connection to the positive terminal of the battery (+12). For optimum performance 4 gauge cable is recommended.

REM (REMOTE)

Connect to switched +12V from the head unit.

SPEAKER OUTPUTS

Amplifier connection to the loudspeaker. Minimum speaker cable is 12 gauge. Minimum impedance for the *Quota* is 1 Ω .

3. Installation

3.1 Installation considerations

If you choose to install the amplifier by yourself, please read the owners' manual carefully. Before you start your installation, please take all steps into consideration. If in doubt, please go to www.b2audio.com for authorized distributors / dealers that will be able to configure your set up.

Feel free to contact us directly for support.

Preparation

Disconnect the negative (-) battery cable before mounting or making any connection. Check the battery and alternator ground (-) connection. Make sure they are properly connected and free of corrosion. Before selecting a mounting location for the amplifier, please take cooling and safety into consideration.

The amplifiers have been designed with a good heat dissipation heatsink. In order to avoid excessive heat from the amplifier, it is recommended to find a mounting location that allows for vertical positioning of the heat sink fins.

For safety purposes, install the amplifier in a dry and well ventilated location and make sure no cables or other harness of the car is interfaced with the mounting location or will present a hazard to the car's cable, control cables, fuel lines/tanks, hydraulic lines or other components of the vehicle.

3.2 Power connectors

12V (Power connection)

Before mounting the amplifier, disconnect the negative (-) wire from the battery to protect any accidental damage to the amplifier or the audio system.

The *Quota* is equipped with 4 AWG power and ground terminals. Connect the power cables to power terminal labeled as + 12V.

The *Quota* uses external fuses. The correct rating is 90A. Connect one end of the fuse holder to the power cable and the other end of the fuse holder to the positive battery terminal within 20 cm of the same cable. This fuse location will protect the system and the vehicle against the possibility of a short circuit in the power cable.

Make sure that the fuses and the fuse holder is adequate for the desired application.

GND (Ground connection)

Locate a secure grounding connection as close as possible to the amplifier. Make sure the location is clean and provides a direct electrical connection to the chassis of the vehicle. Connect one end of an equal sized cable as the positive cable to the location of ground. It is important that the ground cable is as short as possible, but no longer than 75 cm at maximum. Run one end of the cable to the grounding point. Run the other end of the cable to the mounting location. Connect the ground cable to the terminal labeled as GND.

REM (REMOTE CONNECTION)

Run a remote turn on cable from the switched + 12V source. This may be a toggle switch, a relay, the source unit's remote output cable or power antenna trigger cable. Connect the remote turn on cable to the power terminal labeled as REM.

3.3 Installation

+12V, GND, REM connection chart

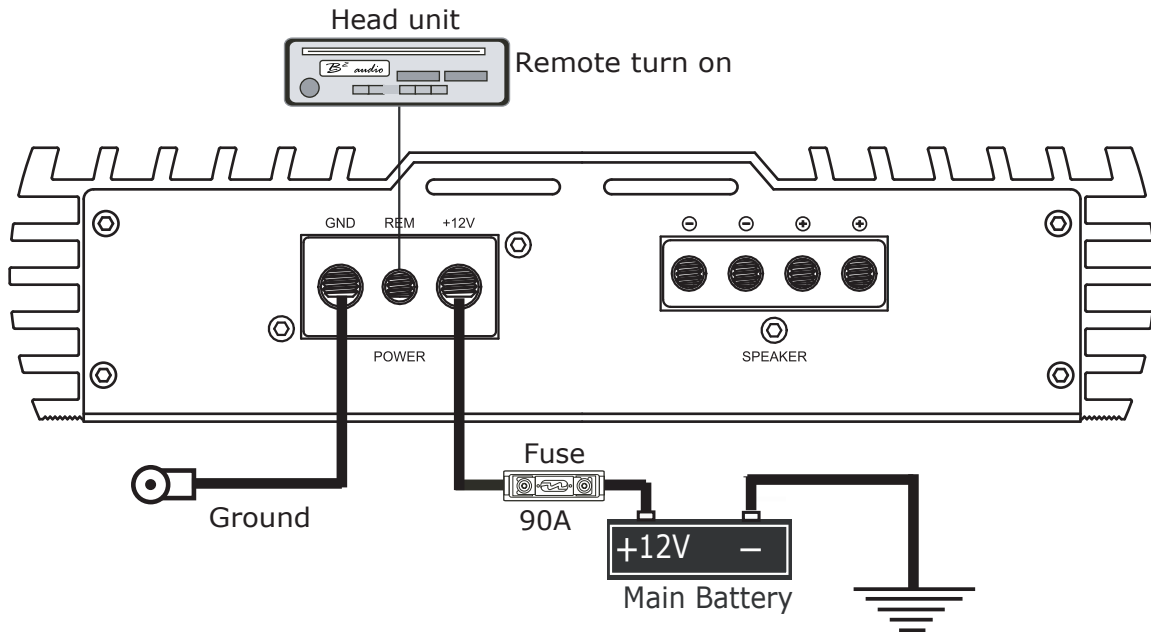

Wiring layout

We recommend using 12 AWG speaker cables to obtain increased performance.

Run 12 AWG speaker cables from your speakers to the amplifier's mounting location. Keep the speaker cables separate from the power cables and the amplifier's input cables.

Use grommets where the cables have to penetrate the vehicle's chassis.

Connect the speaker wires according to the terminals on each speaker.

Strip 3/8" of insulation of the end of each cable and twist the cables strands together tightly.

Make sure there are no stray strands that might touch other cables or terminals and cause a short circuit.

Crimp spade plugs over the cable ends or tin the ends with solder to provide a solid terminal.

Connect the cable ends to the amplifier as shown in the speaker wiring diagram.

Quota

Speaker wiring diagram

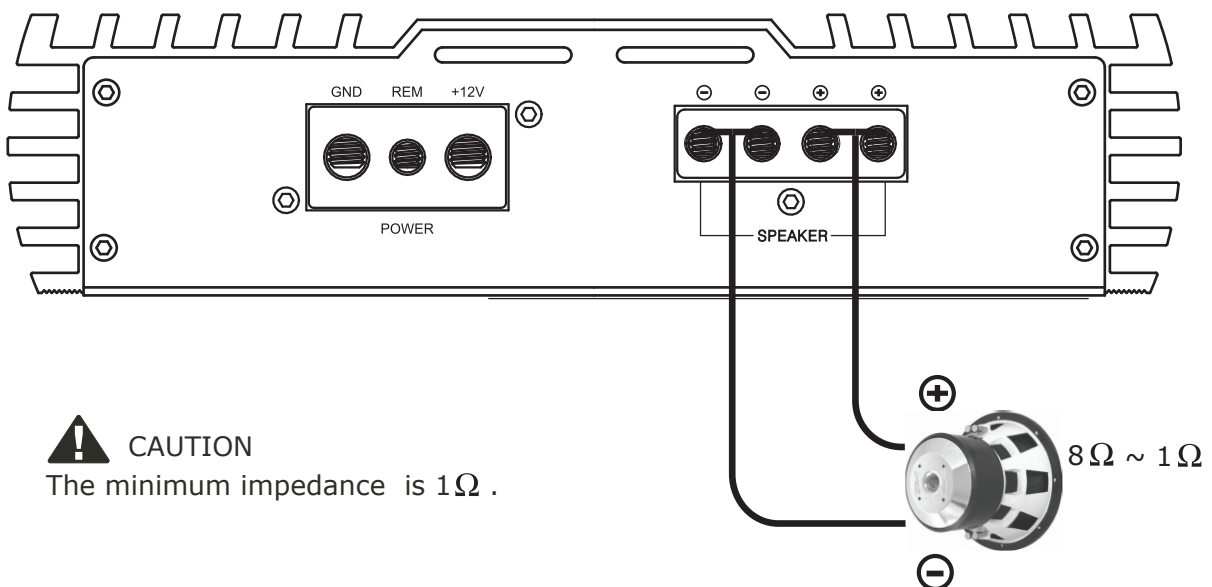

4. Troubleshooting

Assure that the Power LED is on, if so please proceed with step # 3, if not, continue with the steps below;

1. Check the in line fuse (s) on the battery's positive cable, replace if needed.
2. Assure that the Ground is properly attached to the vehicle's chassis on a clean metal point, tighten or grind the connection point once again.
3. Our amplifiers have a low/high voltage protection. Make sure that the voltage is between 9V~16V as voltages outside of this range will cause the amplifier to go into protect.

Protect LED is on

1. The Protect LED will come on due to the possible circumstances;
 - a) The impedance connected is under the specified load.
 - b) Thermal (Overheat), allow for a more suitable mounting as recommended in the install section. Thermal may also appear if the impedance is under the specified or the voltage is inadequate.
 - c) Short circuitry, voltage and DC offset.
 - Short circuitry, go through all cables including speaker wires, GND, battery's positive cable. Voltage, please check step # 3, for DC offset, make sure that a voltage of no more than 4V is available. Remove the RCA from the input and check whether the amplifier comes out of protect. If so, check if the output from the Head unit has a DC of 4V, replace / repair if needed.

Audio output (no sound)

1. Assure that RCA connections from the Head unit and the amplifier is properly connected. Check the entire cable for damages or its like. Test the RCA inputs for AC volts with the source unit on, replace / repair if needed.
2. Check the routing of the cables, fuses and verify that all connections are connected accordingly.
3. Check whether the speakers are functional. This can easily be done by connecting a 9V battery to the speaker terminals which will make the speaker cone move in one direction.

Turn on thump

1. Disconnect the signal input to the amplifier, then turn it on and off.
 - a) If the noise is cancelled, then connect a delay turn on module on the REM wire running from the source unit to the amplifier.
 - b) Use another 12V source for REM lead to the amplifier. If the noise is cancelled, use a relay to isolate the amplifier from the turn on thump.

Poor bass response

1. Check that the polarity of the speaker cables are correct. Speakers connected in anti-phase will cancel each other, thus the bass response will be absent.

Engine noise

1. Ensure that all signal transferring wires (RCA, speaker cables etc) are kept separately / away from the power and the ground wires.
2. Bypass all electrical components between the Head unit and the amplifier. Connect the Head unit directly to the amplifier's input. If the noise is eliminated, the unit bypassed is the one causing the noise.
3. Remove the existing ground wires for all electrical components installed. Ensure that the point of ground is 100% metal which has been grinded free of rust, paint etc.
4. Replace the ground cable from the OEM battery / alternator and ensure it is grounded accordingly.
5. Test the battery and alternator load (can be carried out by a professional). Ensure that the vehicle's electrical system is in a good condition, this includes distributor, spark plugs / wires, voltage regulators etc.

B² audio

Feel free to visit us at: <http://b2audio.com> & at facebook; <http://facebook.com/b2audio>

Bz